

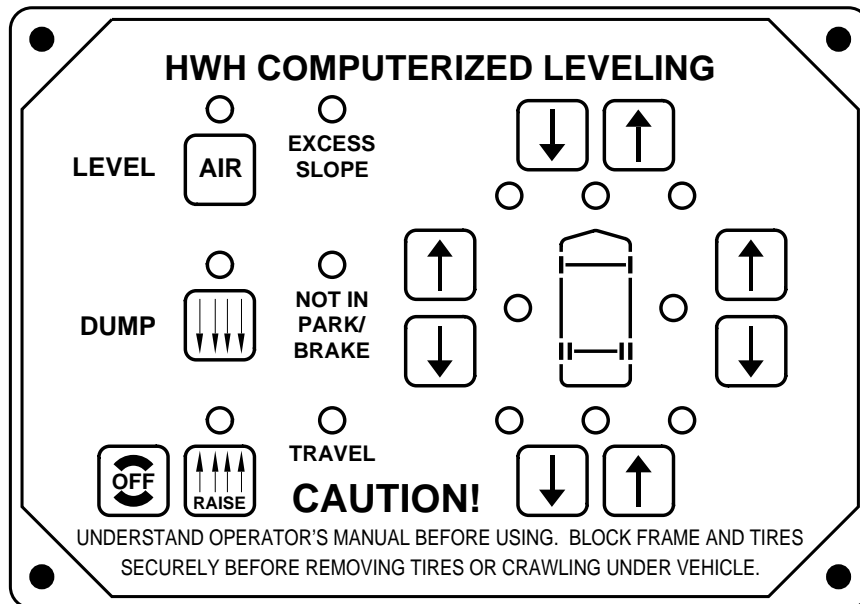

OPERATOR'S MANUAL

HWH COMPUTER-CONTROLLED LEVELING SYSTEM 500 SERIES

FEATURING:
TOUCH PANEL CONTROL
FOUR POINT AIR LEVELING
WITH TAG AXLE



HWH CORPORATION
(ON I-80, EXIT 267 SOUTH)
2096 MOSCOW ROAD
MOSCOW, IOWA 52760
(800) 321-3494 / (563) 724-3396
INTERNET: <http://www.hwhcorp.com>

OPERATOR'S MANUAL

HWH LEVELING SYSTEM AIR LEVELING ONLY

CAUTION !

READ THE ENTIRE OPERATOR MANUAL BEFORE OPERATING.

BLOCK FRAME AND TIRES SECURELY BEFORE CRAWLING UNDER VEHICLE. DO NOT USE LEVELING JACKS OR AIR SUSPENSION TO SUPPORT VEHICLE WHILE UNDER VEHICLE OR CHANGING TIRES. VEHICLE MAY DROP AND/OR MOVE FORWARD OR BACKWARD WITHOUT WARNING CAUSING INJURY OR DEATH.

KEEP ALL PEOPLE CLEAR OF VEHICLE WHILE LEVELING SYSTEM AND ROOM EXTENSION ARE BEING OPERATED.

DO NOT OPERATE LEVELING SYSTEM OR USE THE RAISE OR DUMP BUTTONS WHEN TRAVELING AT SPEEDS IN EXCESS OF 5 MPH.

WEAR SAFETY GLASSES WHEN INSPECTING OR SERVICING THE SYSTEM TO PROTECT EYES FROM DIRT, METAL CHIPS, OIL LEAKS, ETC. FOLLOW ALL OTHER APPLICABLE SHOP SAFETY PRACTICES.

IMPORTANT: IF COACH IS EQUIPPED WITH A ROOM EXTENSION, READ ROOM EXTENSION SECTION BEFORE OPERATING LEVELING SYSTEM.

HOW TO OBTAIN WARRANTY SERVICE

THIS IS NOT TO BE INTERPRETED AS A STATEMENT OF WARRANTY

HWH CORPORATION strives to maintain the highest level of customer satisfaction. Therefore, if you discover a defect or problem, please do the following:

FIRST: Notify the dealership where you purchased the vehicle or had the leveling system installed. Dealership management people are in the best position to resolve the problem quickly. If the dealer has difficulty solving the problem, he should immediately contact the Customer Service Department, at HWH CORPORATION.

SECOND: If your dealer cannot or will not solve the problem, notify the Customer Service Department:
HWH CORPORATION 2096 Moscow Rd. Moscow IA. 52760
(563) 724-3396 OR (800) 321-3494. Give your name and address, coach manufacturer and model year, date the coach was purchased, or the date of system installation,

description of the problem, and where you can be reached during business hours (8:00 a.m. till 5:00 p.m. c.s.t.). HWH CORPORATION personnel will contact you to determine whether or not your claim is valid. If it is, HWH CORPORATION will authorize repair or replacement of the defective part, either by appointment at the factory or by the authorization of an independent service facility, to be determined by HWH CORPORATION. All warranty repairs must be performed by an independent service facility authorized by HWH CORPORATION, or at the HWH CORPORATION factory, unless prior written approval has been obtained from proper HWH CORPORATION personnel.

CONTROL IDENTIFICATION

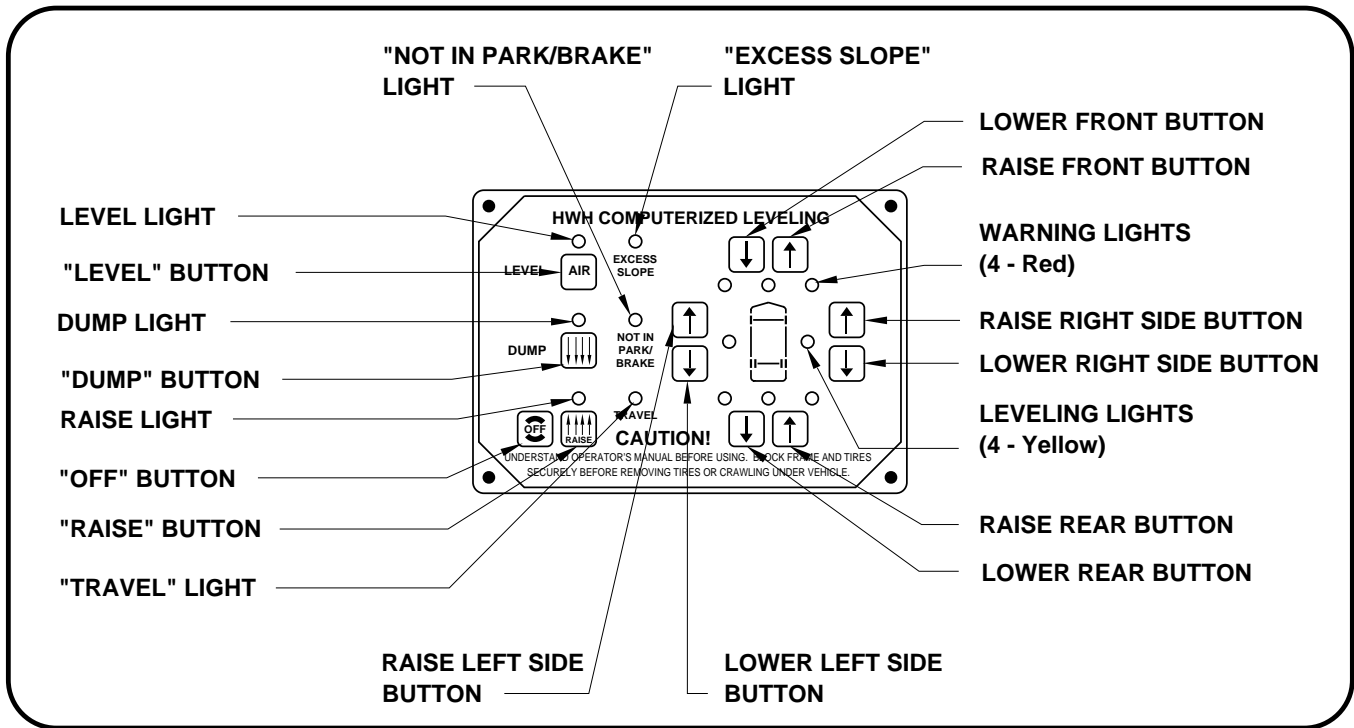

CONTROL FUNCTIONS

CONTROL BUTTONS

"LEVEL" BUTTON: This button is the system on button and automatic operation button.

"OFF" BUTTON: This button will turn the system OFF, but does NOT control power to the "DUMP" or "RAISE" buttons.

"RAISE" BUTTON: This button will raise the whole vehicle by adding air to the suspension system.

"DUMP" BUTTON: This button will lower the whole vehicle by exhausting air from the suspension system.

UP ARROWS (RAISE BUTTONS): These momentary buttons are used to manually operate the air leveling systems. Sides or ends of the vehicle will raise while these buttons are pushed.

DOWN ARROWS (LOWER BUTTONS): These momentary buttons are used to manually operate the air leveling systems. Sides or ends of the vehicle will lower while these buttons are pushed.

INDICATOR LIGHTS

LEVEL LIGHT: This light will be on when the system is on, and flash during automatic leveling.

DUMP LIGHT: This light will flash when the "DUMP" button is being pushed.

RAISE LIGHT: This light will flash when the "RAISE" button is being pushed.

"EXCESS SLOPE" LIGHT: This light will be on if the leveling system can NOT level the coach.

"TRAVEL" LIGHT: This light will be on if the leveling system is off and the ignition is in the "ON" or "ACC" position. See "PREPARATION FOR TRAVEL".

WARNING LIGHTS: These lights will function only with the ignition key in the "ON" or "ACC" position. If the system is on, all four lights will be on. If the system is off and an air bag has low pressure, its respective red light will be on.

LEVELING LIGHTS: One or two yellow lights can be on indicating the side, end or corner of the coach is low.

"NOT IN PARK/BRAKE" LIGHT: This light will be on if the "AIR" button is pushed and the park brake is not set if the ignition switch is in the "ON" position.

OPERATING PROCEDURES

GENERAL INSTRUCTIONS

Press the "OFF" button at any time to stop the operation of the system.

NOTE: If the ignition switch is "ON" the vehicle's air suspension may return to travel height.

If the ignition is in the "ON" position and the hand/auto brake is not set, the "NOT IN PARK" light will come on and the system will not operate when the "AIR" button is pressed. The "NOT IN PARK" light will remain on only while the "AIR" button is pressed.

When using any leveling or "RAISE" functions, the TAG AXLE DUMP should not be used.

The "DUMP" and "RAISE" buttons will function with the system and park brake off if the ignition is "ON". See "AIR DUMP AND RAISE FUNCTIONS".

The two front AIR BAG warning lights will come on if its respective bag has low air pressure and the ignition is "ON" or in "ACC". The system does not have to be on. The master "AIR BAG" warning light will also be on.

CAUTION: DO NOT MOVE THE COACH WHEN THE AIR BAG WARNING LIGHTS ARE ON.

PREPARATION FOR TRAVEL

Start the vehicle's engine and allow air pressure to build to the recommended level for traveling.

Before traveling, the red AIR BAG warning lights must be off and the "TRAVEL" light must be on.

AIR OPERATION

AUTOMATIC AIR LEVELING

IMPORTANT: Do not use the tag axle dump before leveling the vehicle. The tag axle should not be in the raised position when leveling.

1. Set the hand/auto brake in the recommended position for parking. Leave the engine running to provide air for leveling.
2. Press the "AIR" button once to enter the air mode. The AIR indicator light and the four AIR BAG warning lights will glow steady.
3. Press the "AIR" button a second time. The AIR indicator light will start flashing and the air leveling will begin.

4. When all four yellow LEVEL SENSING lights are out the leveling is complete. The AIR indicator light will stop flashing and turn steady red. The processor is now in a SLEEP MODE for 30 minutes. The vehicle's engine may now be turned off.

After 30 minutes the processor will recheck the vehicle level, make any corrections required, and return to the SLEEP MODE. This will continue until the system is turned off by pushing the "OFF" button or the transmission is taken out of the parking position and the park brake is released.

If the system was unable to level the vehicle, one or two yellow LEVEL SENSING indicator lights will remain on and the "EXCESS SLOPE" light will come on. The system will remain on but will not go into SLEEP MODE.

MANUAL AIR LEVELING

IMPORTANT: Do not use the tag axle dump before leveling the vehicle. The tag axle should not be in the raised position when leveling.

1. Place the hand/auto brake in the recommended position for parking. The engine should be running to provide air for leveling.
2. Press the "AIR" button. The "AIR" indicator light will glow steady.
3. Individual RAISE and LOWER buttons (UP and DOWN ARROWS) will add or dump air from suspension air bags to raise or lower coach for leveling. These are momentary buttons. The function will stop when the button is released.

NOTE: The "RAISE" and "DUMP" buttons can be used at this time, but the system will shut off after the button is released.

The yellow LEVEL lights indicate a side, end, or corner of the coach is low. Lower the opposite side or end of the coach to achieve leveling. If a level position cannot be achieved by dumping air, raise the coach according to lit yellow "LEVEL" lights.

IMPORTANT: Always give preference to any side light before leveling the coach front to rear.

4. Turn ignition switch "OFF". Turn the system off.

OPERATING PROCEDURES

AIR OPERATION (CONTINUED)

AIR DUMP AND RAISE FUNCTIONS

IMPORTANT: Do not use the "raise" function if the tag dump is being used or if the tag axle is in the raised position.

The "DUMP" and "RAISE" functions are provided for operator convenience for purposes such as dumping air suspension when parked. The "DUMP" and "RAISE" buttons will function with the system on or off.

IMPORTANT: "DUMP" and "RAISE" functions will automatically turn off when the button is released. If the ignition is in the "ON" position the suspension will return to travel height.

CAUTION: REREAD CAUTIONS ON THE FIRST PAGE OF THIS MANUAL. THE VEHICLE MAY DROP OR RAISE AND/OR MOVE FORWARD OR BACKWARD WITHOUT WARNING CAUSING INJURY OR DEATH.

DO NOT OPERATE THE VEHICLE UNLESS THE AIR SUSPENSION IS AT THE PROPER HEIGHT FOR TRAVEL.

1. Leave the engine running if the "RAISE" function is to be used. The park brake does not have to be set and the system does not have to be on to use the "RAISE" or "DUMP" functions.
2. Press and hold the "RAISE" or "DUMP" button as desired to raise or lower the vehicle. The system will remain in the "RAISE" or "DUMP" mode as long as the button is held down. When the button is released the system will automatically turn off. If the ignition is in the "ON" position the suspension will return to travel height.

MAINTENANCE

OPERATIONAL CHECK

Review the operator's manual and check that all functions and lights work correctly.

"NOT IN PARK/BRAKE" Check: Set hand/auto park brake. Set the transmission in the recommended position for parking the vehicle. Turn the ignition on. Push the "AIR" button on the touch panel. Release the hand/auto park brake.

CAUTION: THE VEHICLE MAY MOVE FORWARD OR BACKWARD WHEN THE PARK IS RELEASED.

Check that the "NOT IN PARK/BRAKE" light comes ON. Reapply the park brake. The "NOT IN PARK/BRAKE" light should go out.

NOTE: IF ANY CHECKS REVEAL ANY PROBLEMS OR IF THERE ARE OTHER PROBLEMS OR QUESTIONS, CONSULT A QUALIFIED RV REPAIR CENTER, YOUR VEHICLE OR COACH MANUFACTURER OR HWH CORPORATION FOR SERVICE OR ASSISTANCE.

LEVEL SENSING UNIT ADJUSTMENT

Level the vehicle by placing a circular bubble level in the center of the freezer floor or location within the vehicle that is to be level. With the vehicle level, adjust the sensing unit until all yellow lights are off. This is done by drawing up the corresponding screw if the sensing unit is mounted below the surface as shown in FIGURE 1 or backing out the corresponding screw if the sensing unit is mounted above the surface. Bump the sensing unit to see that it has settled down in the level position.

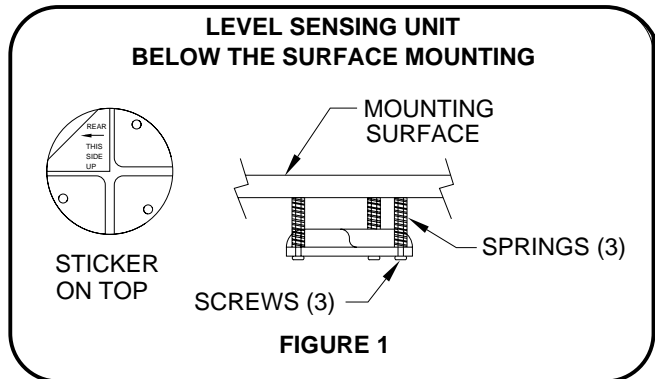

AIR LINE CONNECTION DIAGRAM FRONT AND DRIVE

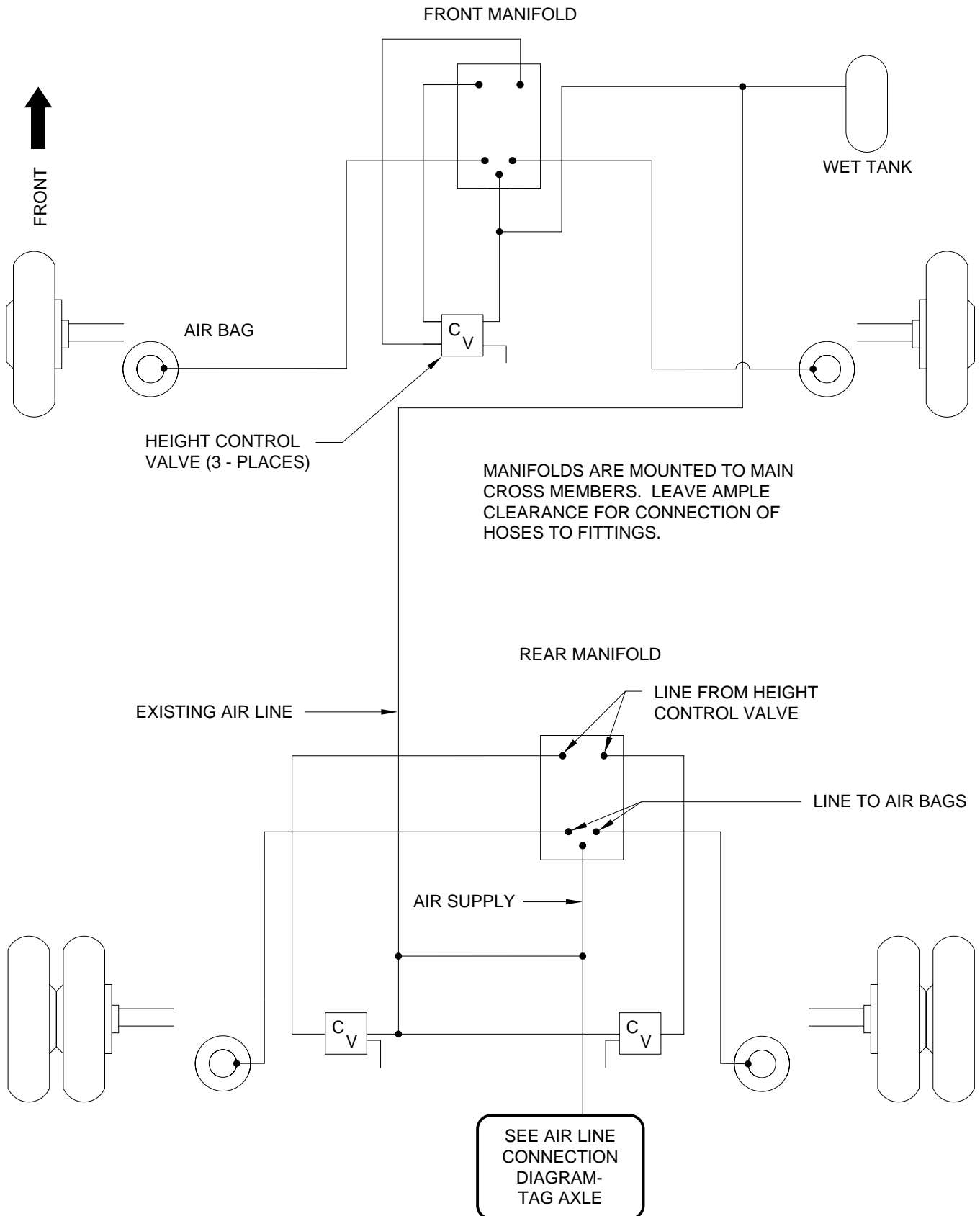

AIR LINE CONNECTION DIAGRAM TAG AXLE

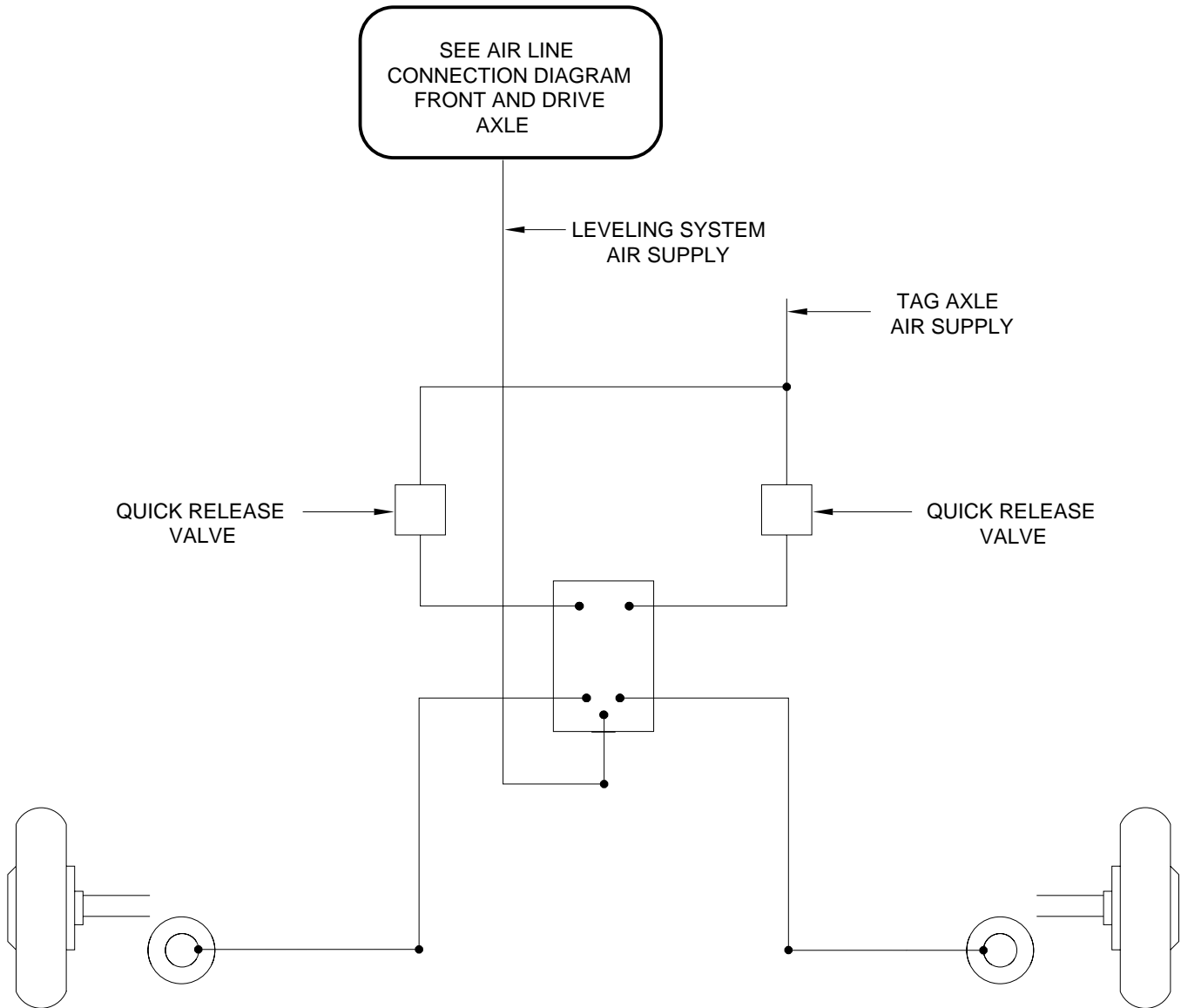

AIR LEVEL SCHEMATIC - GILLIG WITH TAG

4 - POINT LEVELING

WITH PRESSURE SWITCHES FRONT AND REAR

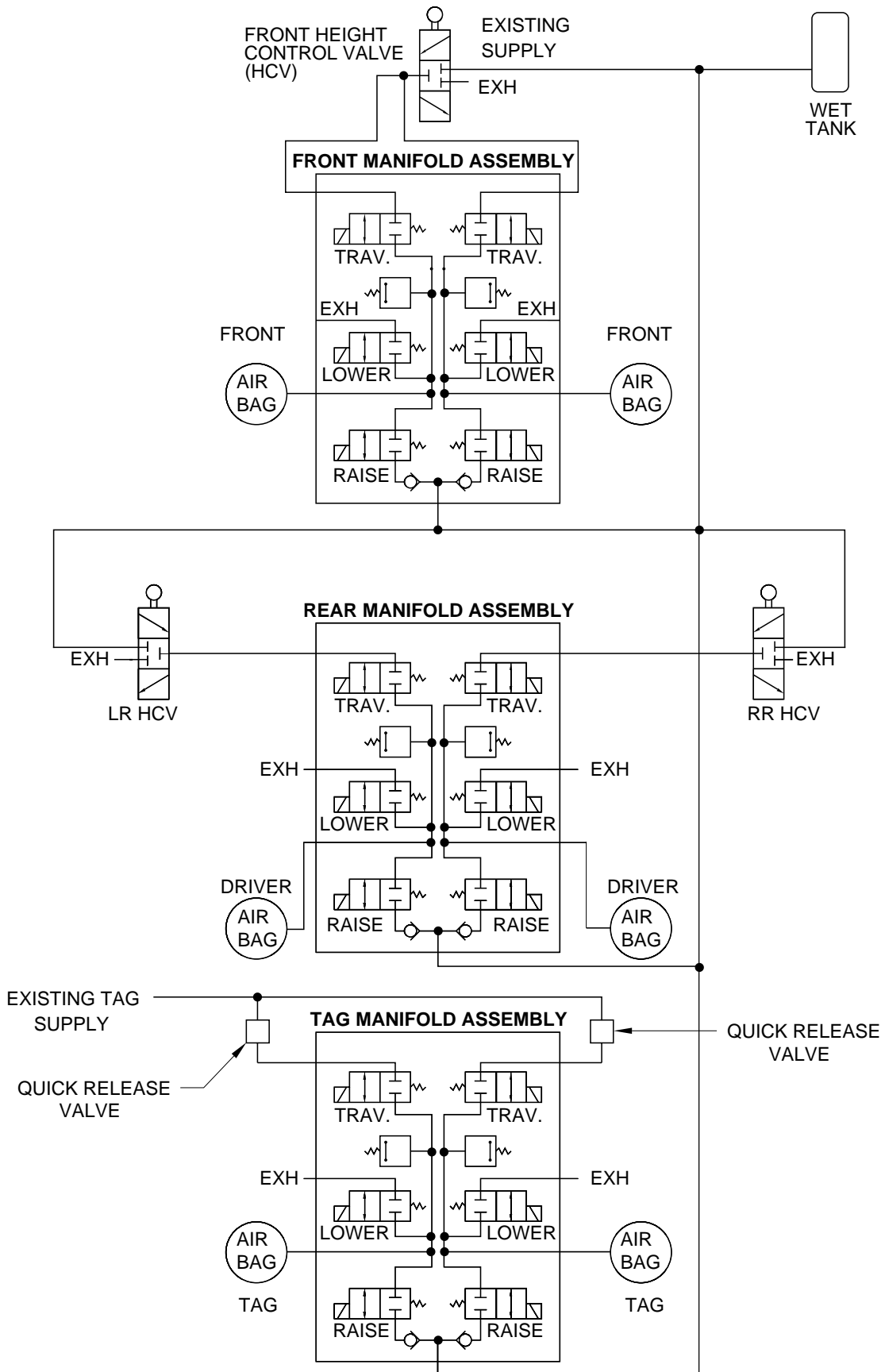

AIR SOLENOID MANIFOLD 6 VALVE WITH TWO PRESSURE SWITCHES

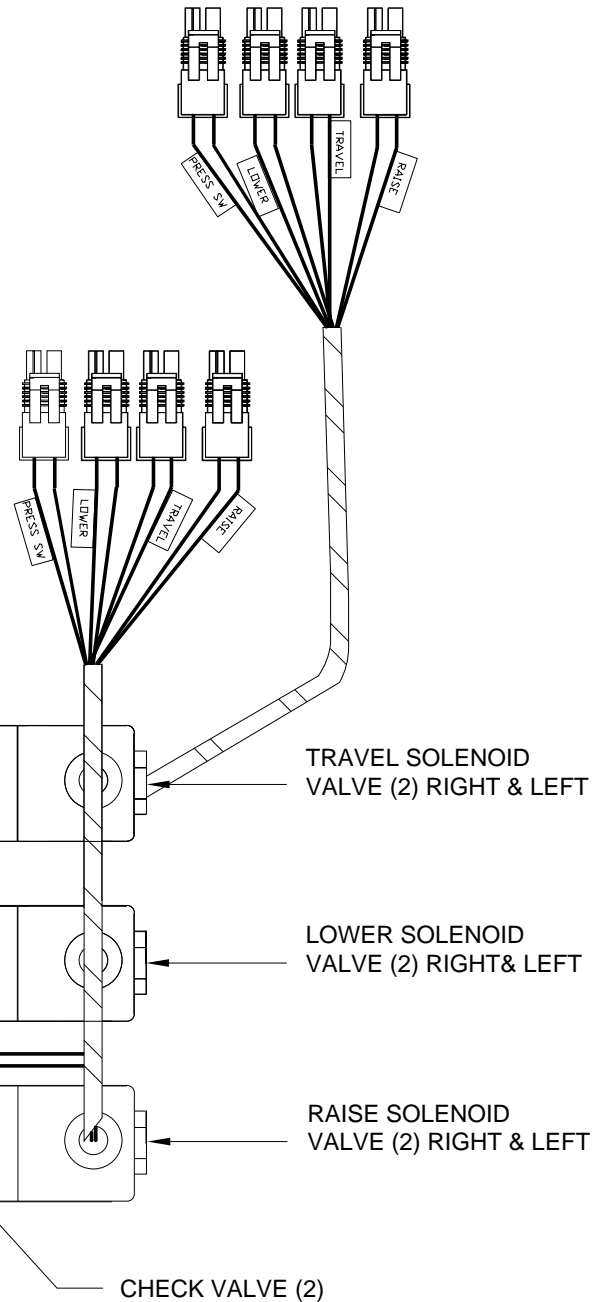
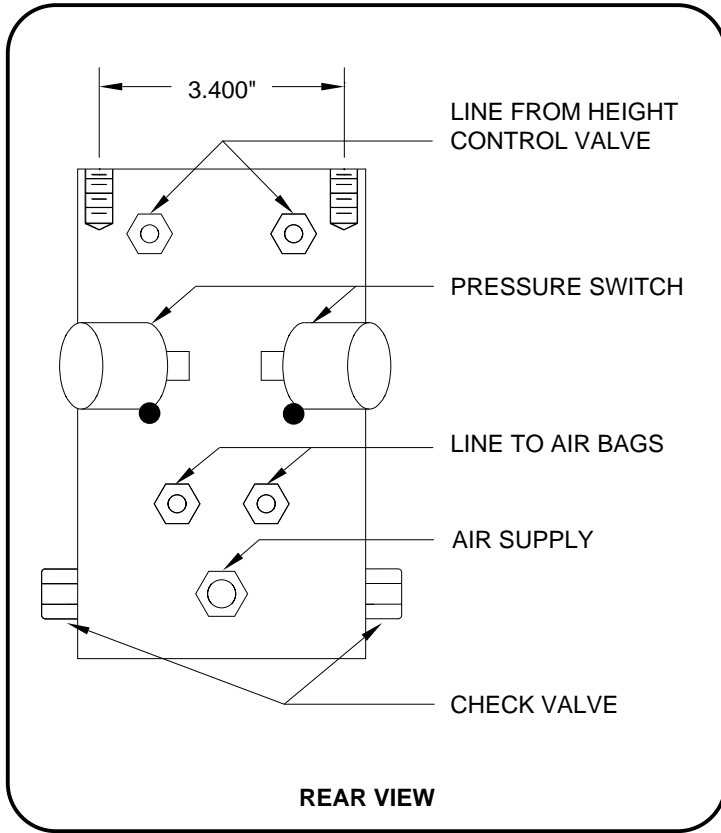

ELECTRICAL CONNECTION DIAGRAM AIR LEVELING SYSTEM WITH TOUCH PANEL CONTROL

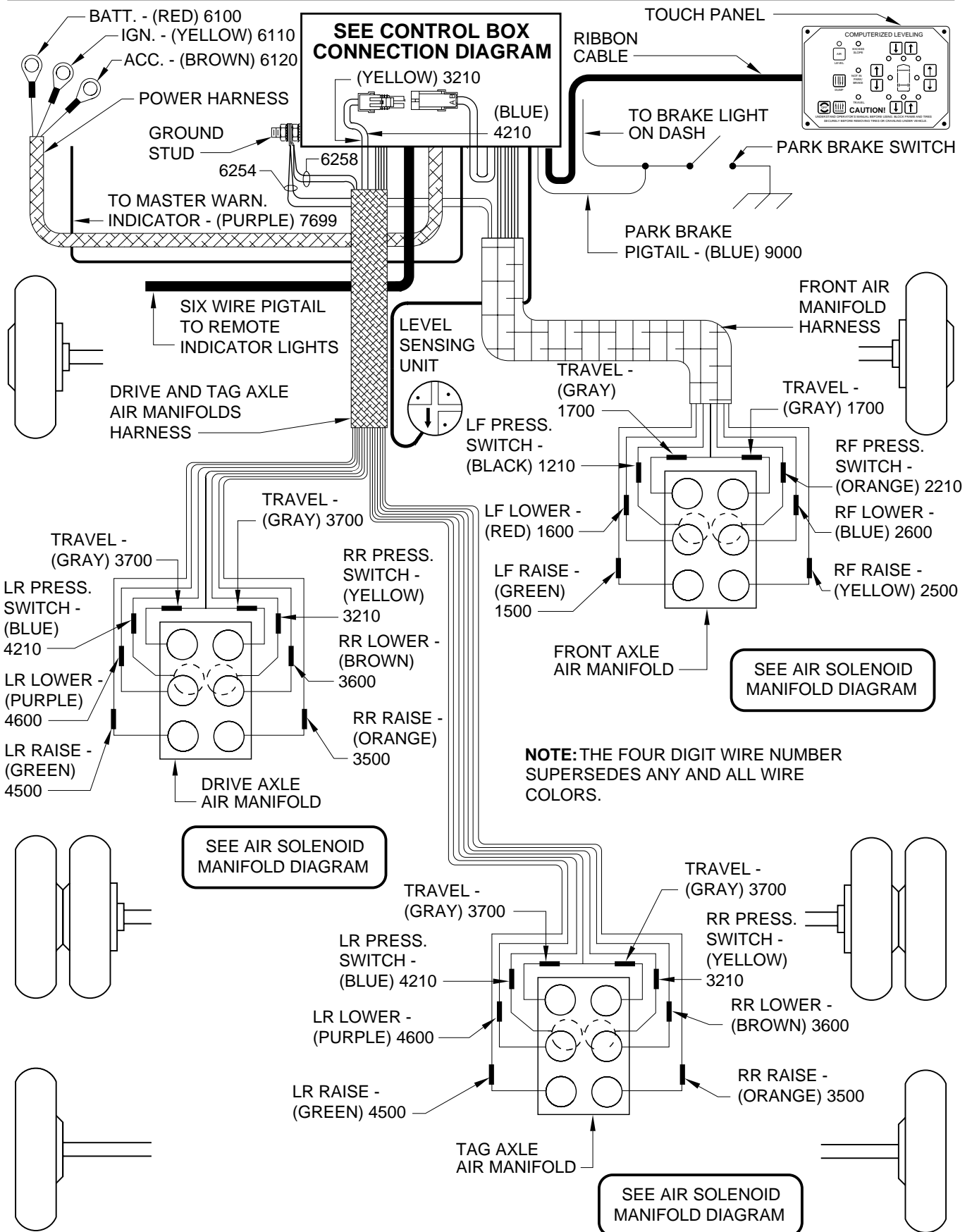

CONTROL BOX CONNECTION DIAGRAM

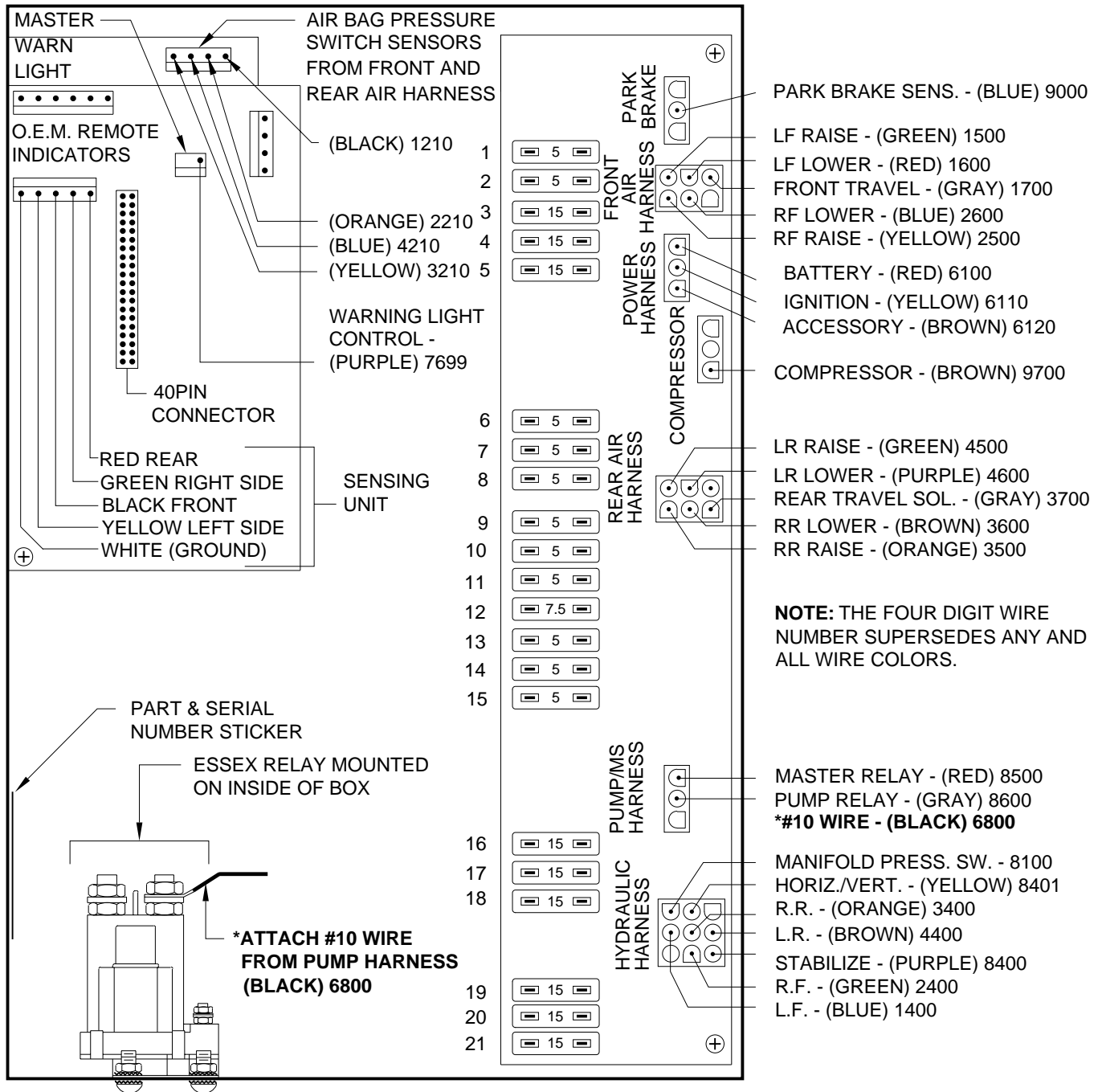

FUSE DESIGNATION

- | | |
|---------------------|-------------------------|
| 1 RIGHT FRONT LOWER | 12 TRAVEL |
| 2 RIGHT FRONT RAISE | 13 TRANSMISSION SW. |
| 3 BATTERY | 14 MASTER RELAY |
| 4 IGNITION | 15 PUMP |
| 5 ACC | 16 RIGHT REAR SOLENOID |
| 6 RIGHT REAR LOWER | 17 HOR/VERT SOLENOID |
| 7 LEFT REAR LOWER | 18 LEFT FRONT SOLENOID |
| 8 LEFT REAR RAISE | 19 RIGHT FRONT SOLENOID |
| 9 RIGHT REAR RAISE | 20 STAB. SOLENOID |
| 10 LEFT FRONT RAISE | 21 LEFT REAR SOLENOID |
| 11 LEFT FRONT LOWER | |

